

0402 AS

Engineer's Kit : EK-0402AS-X

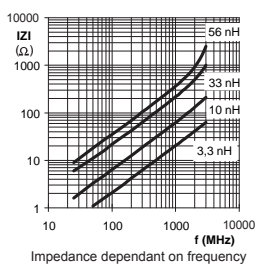
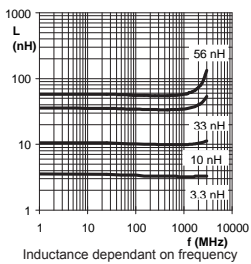
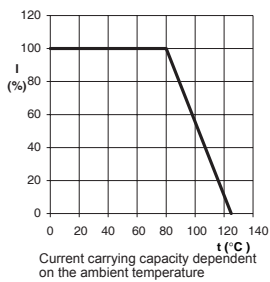
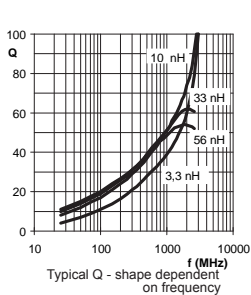
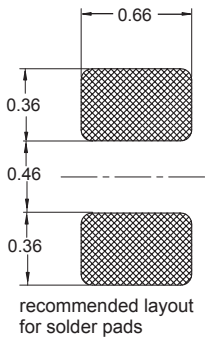
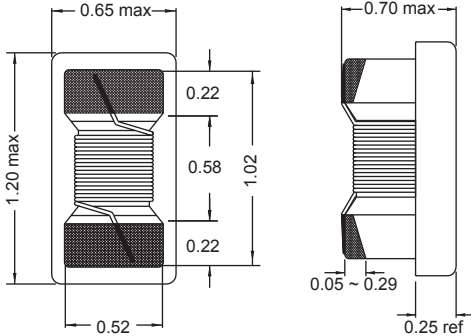
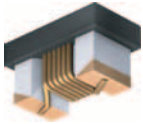

Part No	Inductance L (nH)	f _L (MHz)	Tol ± (%)	Q min	f _a (MHz)	SRF min (MHz)	DCR max (Ω)	Rated DC Current max (mA)
0402AS-0N9X-01	0.9	250	5,10	11	250	6000	0.04	1360
0402AS-1N0X-01	1.0	250	5,10	11	250	6000	0.07	700
0402AS-1N2X-01	1.2	250	5,10	11	250	6000	0.11	700
0402AS-1N8X-01	1.8	250	5,10	16	250	6000	0.07	1040
0402AS-1N9X-01	1.9	250	5,10	16	250	6000	0.07	1040
0402AS-2N0X-01	2.0	250	5,10	16	250	6000	0.07	1040
0402AS-2N2X-01	2.2	250	5,10	14	250	6000	0.11	640
0402AS-2N4X-01	2.4	250	5,10	16	250	6000	0.12	640
0402AS-2N5X-01	2.5	250	5,10	16	250	6000	0.12	640
0402AS-2N7X-01	2.7	250	5,10	16	250	6000	0.12	640
0402AS-2N9X-01	2.9	250	5,10	16	250	6000	0.10	700
0402AS-3N3X-01	3.3	250	5,10	20	250	6000	0.10	700
0402AS-3N6X-01	3.6	250	5,10	19	250	6000	0.10	700
0402AS-3N9X-01	3.9	250	5,10	19	250	4800	0.10	700
0402AS-4N3X-01	4.3	250	5,10	18	250	6000	0.091	700
0402AS-4N7X-01	4.7	250	5,10	15	250	4775	0.130	640
0402AS-5N1X-01	5.1	250	5,10	23	250	4800	0.083	800
0402AS-5N6X-01	5.6	250	5,10	22	250	4800	0.110	760
0402AS-6N2X-01	6.2	250	5,10	20	250	4800	0.110	760
0402AS-6N8X-01	6.8	250	5,10	21	250	4800	0.100	680
0402AS-7N5X-01	7.5	250	5,10	24	250	4800	0.100	680
0402AS-8N2X-01	8.2	250	5,10	24	250	4400	0.100	680
0402AS-8N7X-01	8.7	250	5,10	22	250	4160	0.160	681
0402AS-9N0X-01	9.0	250	5,10	22	250	4160	0.160	681
0402AS-9N1X-01	9.1	250	5,10	22	250	4000	0.200	480
0402AS-9N5X-01	9.5	250	5,10	22	250	4000	0.200	480
0402AS-010X-01	10	250	5,10	21	250	3900	0.200	480
0402AS-011X-01	11	250	5,10	24	250	3680	0.170	640
0402AS-012X-01	12	250	5,10	24	250	3600	0.170	640
0402AS-013X-01	13	250	5,10	24	250	3600	0.170	640
0402AS-015X-01	15	250	5,10	24	250	3280	0.170	560
0402AS-016X-01	16	250	5,10	24	250	3100	0.220	560
0402AS-018X-01	18	250	5,10	25	250	3100	0.23	420
0402AS-019X-01	19	250	5,10	24	250	3040	0.24	480
0402AS-020X-01	20	250	5,10	25	250	3000	0.25	420
0402AS-022X-01	22	250	5,10	25	250	2800	0.30	400
0402AS-023X-01	23	250	5,10	22	250	2720	0.30	400
0402AS-024X-01	24	250	5,10	22	250	2480	0.30	400
0402AS-027X-01	27	250	5,10	24	250	2480	0.30	400
0402AS-030X-01	30	250	5,10	24	250	2350	0.30	400
0402AS-033X-01	33	250	5,10	24	250	2350	0.30	320
0402AS-036X-01	36	250	5,10	24	250	2320	0.44	320
0402AS-039X-01	39	250	5,10	25	250	2100	0.55	200
0402AS-040X-01	40	250	5,10	25	250	2100	0.83	150
0402AS-043X-01	43	250	5,10	25	250	2100	0.75	150
0402AS-047X-01	47	250	5,10	25	250	2100	0.83	150
0402AS-051X-01	51	250	5,10	25	250	1760	0.97	100
0402AS-056X-01	56	250	5,10	25	250	1760	0.97	100
0402AS-068X-01	68	250	5,10	25	250	1620	0.97	100
0402AS-072X-01	72	100	5,10	15	100	1070	1.20	80
0402AS-082X-01	82	100	5,10	18	100	1070	1.20	80
0402AS-R10X-01	100	100	5,10	15	100	1070	1.20	80
0402AS-R12X-01	120	100	5,10	12	100	580	1.30	75
0402AS-R13X-01	130	100	5,10	10	100	450	1.30	70
0402AS-R15X-01	150	100	5,10	13	100	400	1.30	60
0402AS-R18X-01	180	50	5,10	10	50	380	1.50	65
0402AS-R20X-01	200	50	5,10	10	50	400	1.50	50
0402AS-R22X-01	220	50	5,10	10	50	190	2.00	50

Material : Ceramic

SPQ : Reel 5000 [-01]
2000 [-08]

Remarks: - For not listed inductance values please check availability with us.
- 2% available on request.