

## Plugable Inductors (Pin Type Coils)

FASTRON plugable inductors offer a wide range of inductance values from 10µH to 150 000µH and a high Q. They come in shielded, tube and cap versions able to protect the winding. They are available in reel packing and ammpack.

**Applications** Applied in DC-DC converters and all types of electronic instruments, such as digital amplifier LPF and signal filtering applications.

### Technical Data

L – Value (rated inductance)	Measured with HP 4194A Impedance / Gain-phase Analyzer at frequency $f_L$
Q – Factor (min)	Measured with HP 4194A Impedance / Gain-phase Analyzer at frequency $f_Q$
SRF (min)	Measured with HP 8714 RF Network Analyzer
DCR (max)	Measured at 25°C
Rated DC Current	I based on temperature rise, determined at the point where the temperature rise does not exceed 40°C above the ambient temperature of 25°C
Operating Temperature	-55°C to +85°C
Recommended soldering method	Wave
Solderability	Using lead free solder (Sn 99.9) at 260°C ± 5°C for 5 ± 0.5 seconds, min 90% solder coverage of metallization Standard: IEC 68-2-20 (Ta)
Resistance to Soldering Heat	Resistant to 260°C ± 5°C for 10 ± 1 seconds Standard: IEC 68-2-20 (Tb)
Resistance to Solvent	Resistant to Isopropyl alcohol for 5 ± 0.5 minutes at 23°C ± 5°C Standard: IEC 68-2-45
Climatic Test	Defined by the following standards IEC 68-2-1 for Cold test: -55°C for 96 hours IEC 68-2-2 for Dry heat test: + 85°C for 96 hours IEC 60068-2-78 for Humidity test: 40°C at RH 95% for 4 days
Thermal Shock Test	Temperature cycle : -55°C to + 85°C to -55°C Max/Min temperature duration: 15 minutes Temperature transition duration: 5 minutes Cycles: 25 Standard: MIL-STD-202G
Tensile Strength of Leads	Components withstand a pulling force of 10N for 10 ± 1 seconds IEC 60068-2-21 (Ua1)
Mechanical Shock	Mil-Std 202 Method 213 Condition C 3 axis, 6 times, total 18 shocks 100 G, 6 ms, half-sine
Vibration	Mil-Std 202 Method 204 20 mins at 5G 10 Hz to 2000 Hz 12 cycles each of 3 orientations

All dimensions are in (mm)

Technical Data & Packing Spec

**Ordering Code** Example: **09P-101X-51**  
 (Model) (Inductance Value) (Tolerance) (Packing Code)

- Core Type - Ferrite
- Tolerances - J (5%), K (10%)
- **Bold is standard tolerance**
- Packing Code - 50 (Loose in Box), 51 (Reel)

### Packing Specification

### Reel Taping (51)

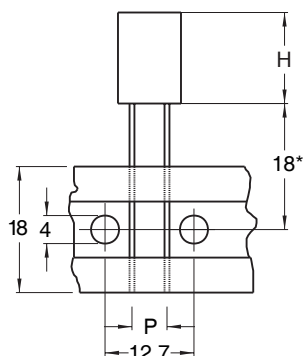

Cap version	H max. (mm)	P
07P/F	11	3.5
09P/F	14	5

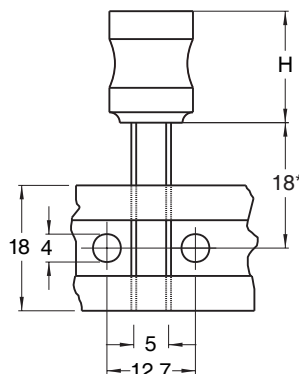

Tube version	H max. (mm)
07P	12
09P	14

\*according to IEC 286 (also available 16mm)