

1210 ASM

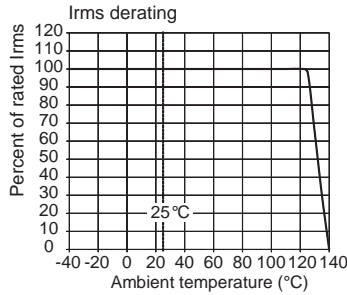

Non-magnetic

Engineer's Kit : EK-1210ASM-X

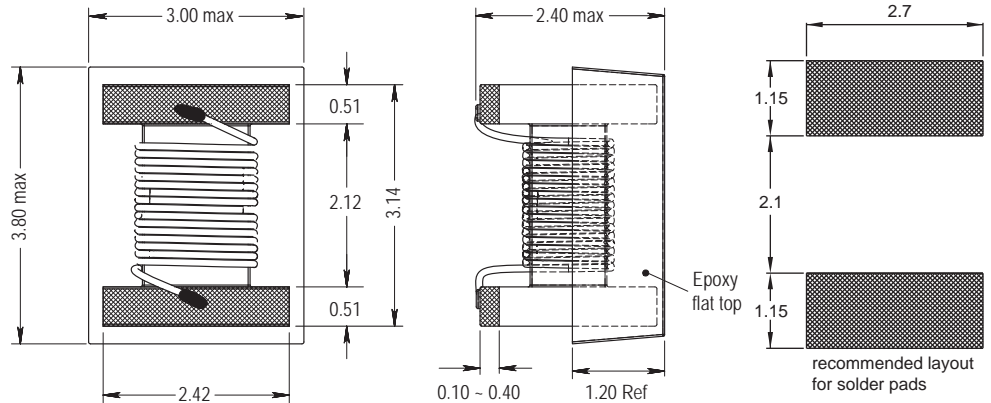
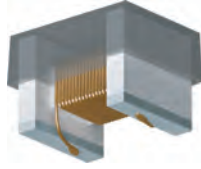

Current carrying capacity dependent on the ambient temperature

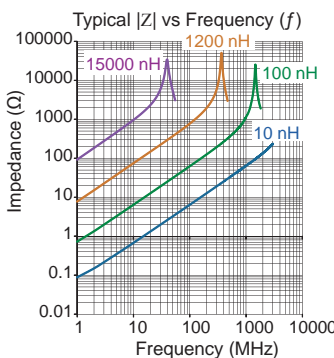
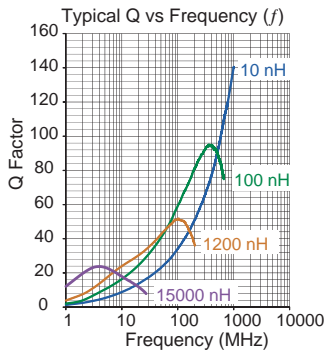
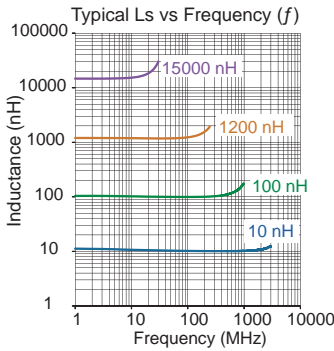

Single layer (typ)

Part No	Inductance L (nH)	f _L (MHz)	Tol ± (%)	Q min	f _Q (MHz)	SRF (MHz)	DCR max (Ω)	Rated DC Current max (mA)
1210ASM-010K-YY	10	50	10	50	500	4100 min	0.08	1000
1210ASM-012K-YY	12	50	10	50	500	2400 min	0.09	1000
1210ASM-015K-YY	15	50	10	50	500	2400 min	0.10	1000
1210ASM-018K-YY	18	50	10	50	350	2400 min	0.11	1000
1210ASM-022K-YY	22	50	10	55	350	2400 min	0.12	1000
1210ASM-027J-YY	27	50	5	55	350	1800 min	0.13	1000
1210ASM-033J-YY	33	50	5	60	350	1600 min	0.14	1000
1210ASM-039J-YY	39	50	5	60	350	1500 min	0.15	1000
1210ASM-047J-YY	47	50	5	65	350	1200 min	0.16	1000
1210ASM-056J-YY	56	50	5	65	350	1200 min	0.16	1000
1210ASM-068J-YY	68	50	5	65	350	1000 min	0.20	1000
1210ASM-082J-YY	82	50	5	60	350	1000 min	0.22	1000
1210ASM-R10J-YY	100	25	5	60	350	1000 min	0.24	980
1210ASM-R12J-YY	120	25	5	60	350	850 min	0.26	920
1210ASM-R15J-YY	150	25	5	50	100	750 min	0.29	870
1210ASM-R18J-YY	180	25	5	50	100	700 min	0.31	830
1210ASM-R22J-YY	220	25	5	50	100	650 min	0.35	790
1210ASM-R27J-YY	270	25	5	45	100	600 min	0.42	730
1210ASM-R33J-YY	330	25	5	45	100	500 min	0.49	680
1210ASM-R39J-YY	390	25	5	45	100	500 min	0.54	640
1210ASM-R47J-YY	470	25	5	45	100	450 min	0.60	610
1210ASM-R56J-YY	560	25	5	45	100	415 min	1.00	460
1210ASM-R68J-YY	680	25	5	45	100	350 min	1.15	420
1210ASM-R82J-YY	820	25	5	45	100	350 min	1.93	350
1210ASM-1R0K-YY	1000	25	10	35	50	290 typ	2.16	330
1210ASM-1R2K-YY	1200	7.9	10	35	50	250 typ	2.38	310
1210ASM-1R5K-YY	1500	7.9	10	25	50	200 typ	2.64	300
1210ASM-1R8K-YY	1800	7.9	10	25	50	160 typ	2.76	290
1210ASM-2R2K-YY	2200	7.9	10	25	50	160 typ	2.98	280
1210ASM-2R7K-YY	2700	7.9	10	25	25	140 typ	3.30	260
1210ASM-3R3K-YY	3300	7.9	10	25	25	120 typ	3.66	250
1210ASM-3R9K-YY	3900	7.9	10	20	25	100 typ	4.00	240
1210ASM-4R7K-YY	4700	7.9	10	20	25	90 typ	4.30	230
1210ASM-5R6K-YY	5600	7.9	10	15	25	60 typ	4.30	230
1210ASM-6R8K-YY	6800	7.9	10	15	25	60 typ	5.20	210
1210ASM-8R2K-YY	8200	7.9	10	17	7.9	45 typ	5.90	168
1210ASM-100K-YY	10000	7.9	10	17	7.9	38 typ	6.00	160
1210ASM-150K-YY	15000	7.9	10	15	7.9	20 typ	7.00	120

Core Material : Ceramic

Revision date : 03 Sep 2020

SPQ : Taped / Reel 800 [-01]
3000 [-04]

Remarks : - Unlisted inductance values available upon request.
- 2% and 5% tolerance available upon request.