

## Leaded Inductors (Fixed Choke Coils)

FASTRON leaded inductors come with a very wide inductance range from 0.1µH to 100000µH and with high Q values. They are available in tape and ammpack packing.

**Applications** These components are suitable for decoupling and interference suppression.  
Communication: RF blocking and filtering, e.g. 12 ~ 16 kHz blocking filter.  
Others: Automotive electronics, electronic household appliances, entertainment electronics, lighting devices, medical applications.

### Technical Data

L – Value (rated inductance)	Measured with Bode 100 Vector Network Analyzer or equivalent at frequency $f_L$
Q – Factor (min)	Measured with Bode 100 Vector Network Analyzer or equivalent at frequency $f_Q$
SRF (min)	Measured with HP 8753ES Network Analyzer or equivalent
DCR (max)	Measured at 25°C
Rated DC Current	I based on temperature rise, determined at the point where the temperature rise does not exceed 40°C above the ambient temperature of 25°C I1 Current based on ambient temperature of 40°C and component temperature of max. 125°C Isat Current based on inductivity drop of 10% related to the unloaded inductivity
Operating Temperature	-55°C to +125°C (including component self-heating)
Recommended soldering method	Wave
Solderability	Using lead free solder (Sn 99.9) at 260°C ± 5°C for 5 ± 0.5 seconds, min 90% solder coverage of metallization Standard: IEC 68-2-20 (Ta)
Resistance to Soldering Heat	Resistant to 260°C ± 5°C for 10 ± 1 seconds Standard: IEC 68-2-20 (Tb)
Resistance to Solvent	Resistant to Isopropyl alcohol for 5 ± 0.5 minutes at 23°C ± 5°C Standard: IEC 68-2-45
Climatic Test	Defined by the following standards IEC 68-2-1 for Cold test: -55°C for 96 hours IEC 68-2-2 for Dry heat test: +125°C for 96 hours IEC 60068-2-78 for Humidity test: 40°C at RH 95% for 4 days
Tensile Strength of Leads (Pull Test)	Components withstand a pulling force of 10N for 10 ± 1 second For MICC, MICC/N, MICCS, MICCS/N : Components withstand a pulling force of 5N for 10 ± 1 second IEC 60068-2-21 (Ua1)
Mechanical Shock	Mil-Std 202 Method 213 Condition C 3 axis, 6 times, total 18 shocks 100 G, 6 ms, half-sine
Vibration	Mil-Std 202 Method 204 20 mins at 5G 10 Hz to 2000 Hz 12 cycles each of 3 orientations

### Colour Coding Reference according to IEC 60062 :

Code	Nominal Inductance (µH)				Tol. **
	Band 1	Band 2	Band 3	Band 4	
Gold	---	---	x 0.1	± 5 %	J
Silver	---	---	x0.01	± 10 %	K
Clear	---	---	---	± 20 %	M
Black	---	0	x1	---	---
Brown	1	1	x10	± 1 %	F
Red	2	2	x100	± 2 %	G
Orange	3	3	x1000	± 3 %	A
Yellow	4	4	x10000	---	---
Green	5	5	---	---	---
Blue	6	6	---	---	---
Violet	7	7	---	---	---
Grey	8	8	---	---	---
White	9	9	---	---	---

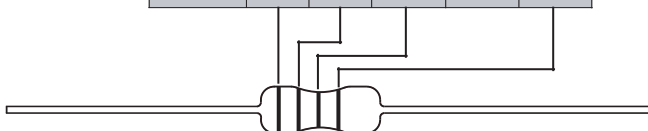

### Ordering Code

Example: **SMCC-180X-YY**

**SMCC** - **180** **X** - **YY**  
(Model) (Inductance Value) (Tolerance) (Packing Code)



**SMCC-180K-01**

Core Type - Ferrite, Phenolic  
Tolerances - F (1%), G (2%), H (2.5%), A (3%), J (5%), K (10%), M (20%)

Packing Code	Packing Form	Taped / Reel	Taped / Ammo pack
	Axial	01	02
	Radial	31	32

**Packing Specification**

**Fig. 1: On Reel (Plastic)**

Packing code : 01, 31

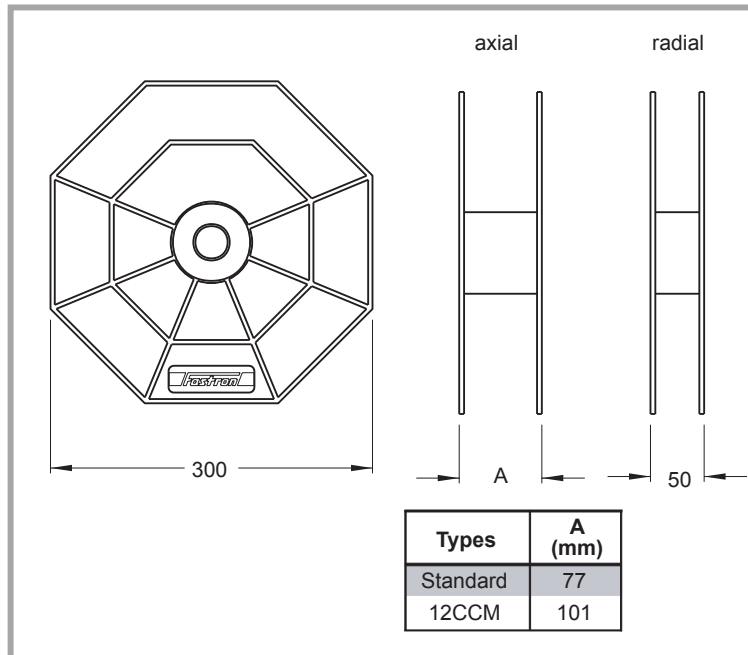

**Fig. 2: Ammo pack, axial**

Packing code : 02

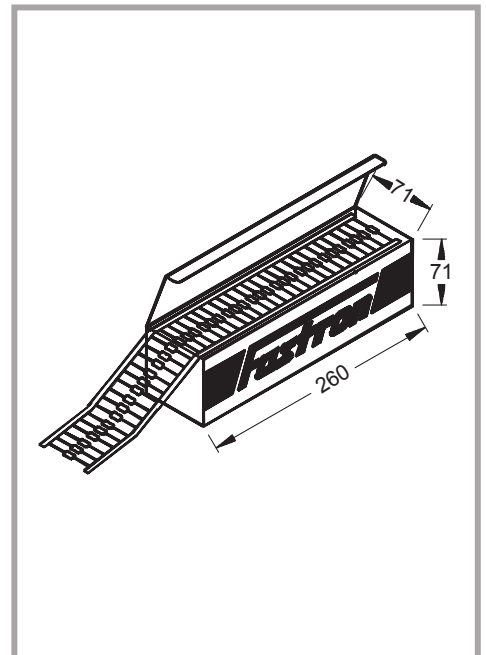

**Fig. 3: Axial Standard Taping**

Packing code : 01, 02

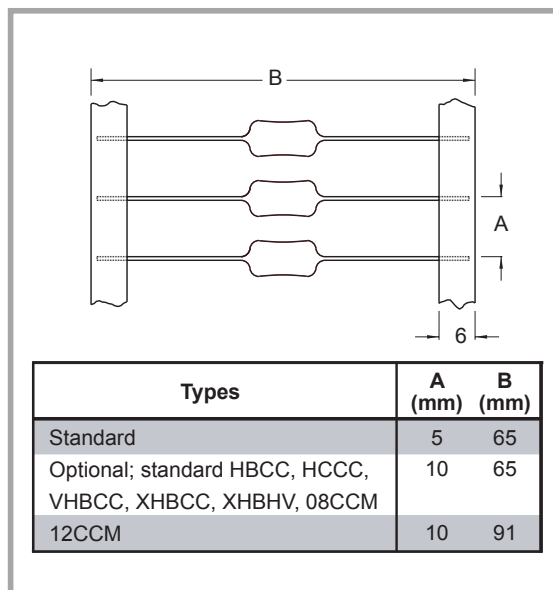

**Fig. 4: Axial Narrow Taping (38mm)**

Packing code : 11, 12

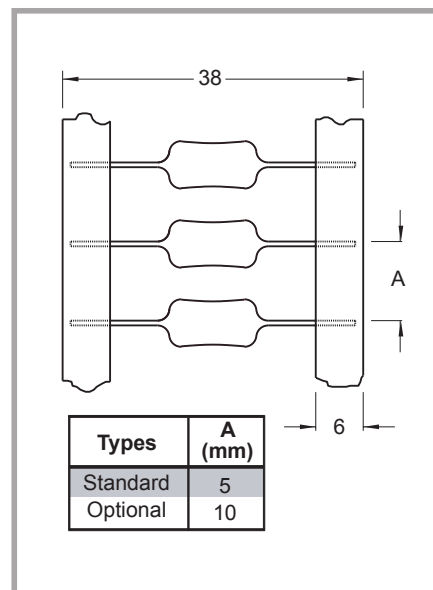

**Packing Specification**

**Fig. 5: Radial Taping**

Packing code : 31, 32

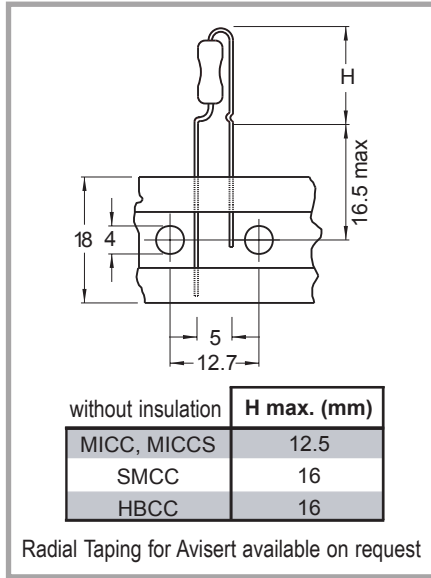

**Fig. 6: Ammo pack, radial**

Packing code : 32

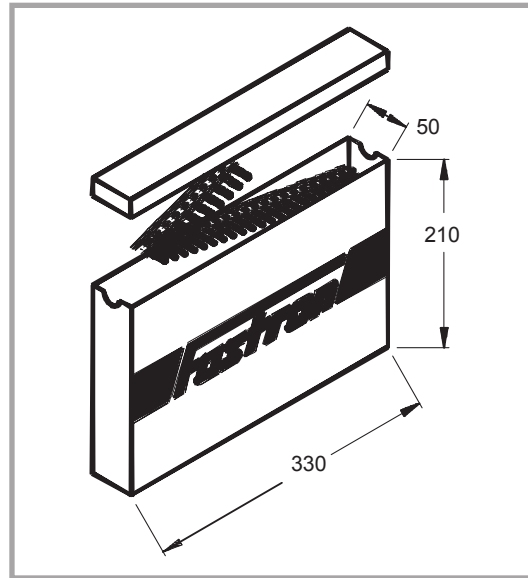

**Fig. 7: Axial preformed**

Packing code : 20

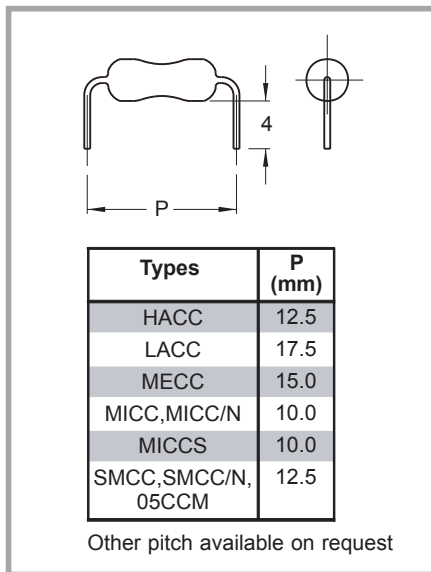

Packing Specification